

CONCRETE CURBING  
BY OTHERS.

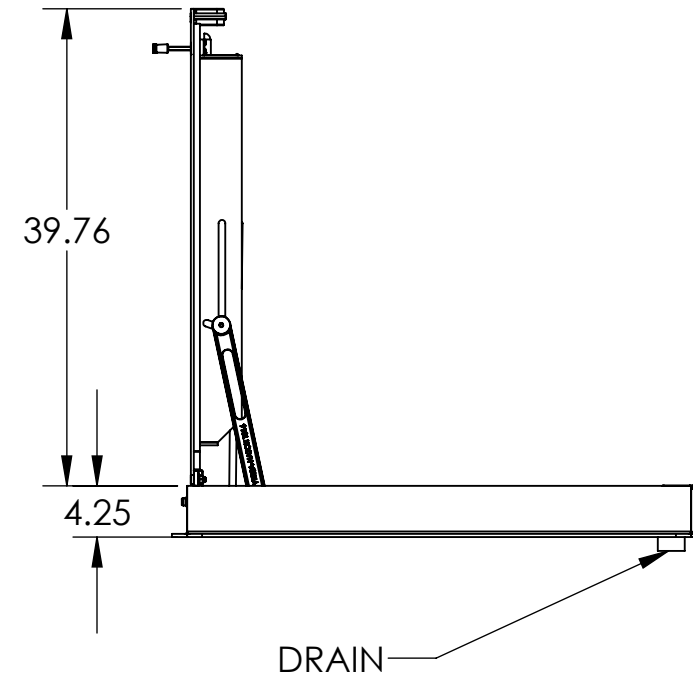
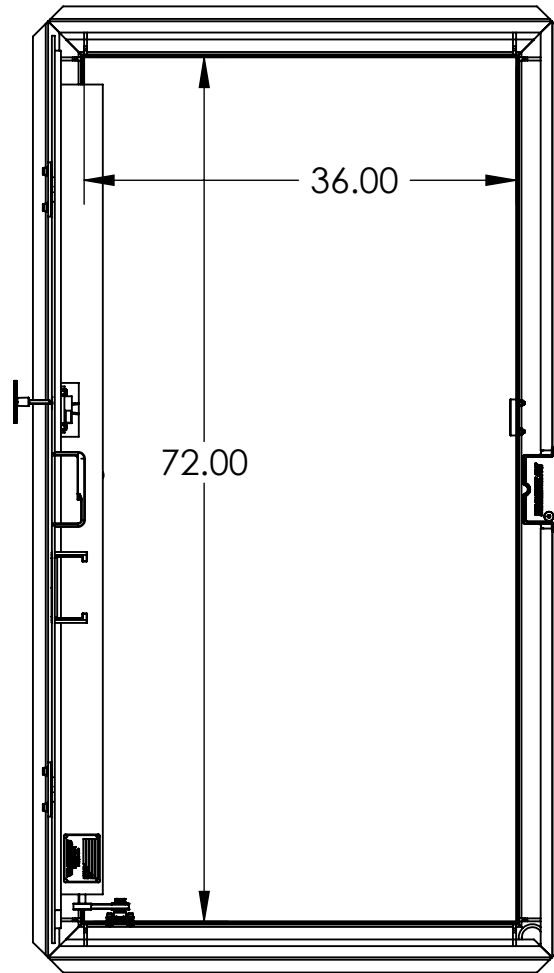

NOTES:  
 PN: VSH-FW300-A-72-36-S-GS  
 DESC: HATCH ASSEMBLY, FW300 SERIES 72 X 36  
 MATRL:  
 EST. WT: 96.07  
 FINISH:  
 NOTE:  
 CAD FILE: VSH-FW300-A-72-36-S-GS-SPEC

THIS DOCUMENT CONTAINS PROPRIETARY, TRADE SECRET INFORMATION THAT IS THE PROPERTY OF VERSA STEEL, INC. THE INFORMATION CONTAINED IN THIS DOCUMENT, INCLUDING THE PRINCIPLE OF DESIGN, MAY NOT BE USED OR COPIED, IN WHOLE OR IN PART, WITHOUT THE EXPRESS PRIOR WRITTEN CONSENT OF VERSA STEEL, INC.

VERSA STEEL, INC.  
 1618 NE FIRST AVENUE  
 PORTLAND, OREGON 97232  
 (503)287-9822  
 FAX (503)-287-7483

DRAWN BY  
 E. BAILIFF  
 DATE  
 2010-11-24  
 CHECKED BY

APPROVED BY

MATERIAL  
 FINISH  
 SHEET TITLE  
 HATCH ASSEMBLY, FW300 SERIES 72 X 36  
 PART NUMBER  
 VSH-FW300-A-72-36-S-GS  
 SUPPLIER  
 PART NUMBER  
 VSH-FW300-A-72-36-S-GS  
 SCALE  
 1:16  
 DRAWING NO.  
 VSH-FW300-A-72-36-S-GS-S  
 REVISION NO.  
 A  
 SHEET NO.  
 2 OF 2

REV	ISSUED FOR	DATE	BY
G			
F			
E			
D			
C			
B			
A			