

VERSA STEEL SPECIFICATION

FLOOR AND SIDEWALK 300 PSF
PEDESTRIAN

HATCH ASSEMBLY, FW300 SERIES 24 X 36

Assembly No.:VSH-FW300-A-24-36-S-GS

ASSEMBLY NO./PART NUMBER KEY:

VSH= VERSA STEEL INC. HATCH
FW300 = FLUSH 300 P.S.F. RATED, CAST IN DRAINABLE FRAME
A= ALUMINUM CONSTRUCTION
36-36= SIZE INTERIOR OPENING
S = SINGLE LEAF
GS= GAS SPRING ASSIST

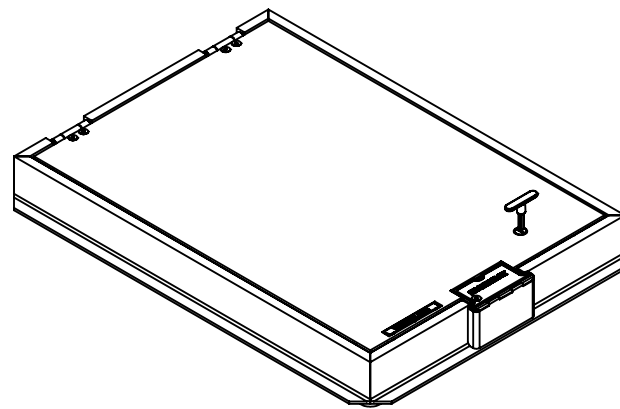

GENERAL SPECIFICATIONS:

1. UNIT IS WEATHER PROOF WITH CONTINOUS EPDM SEAL ON LID TO FRAME.
2. LID TOP IS FLUSH TO FRAME. FRAME IS CONTINOUS EXTRUDED CHANNEL.
3. LID IS HINGED ON SIDE WITH TAMPER PROOF SCREWS AND PROVISION FOR A PADLOCK WITH TAMPER PROOF COVER.
4. HATCH IS DESIGNED FOR 300 P.S.F. LOAD.
5. DESIGNED TO BE CAST IN CONCRETE CURBING AT TOP OF VAULT.
6. LID IS A 1/4" 6061 ALUMINUM TREAD PLATE. OPTIONAL NON-SLIP COATING.
7. ALL FASTENERS AND HARDWARE ARE 316 STAINLESS STEEL.
8. ONE COAT OF BLACK BITUMINOUS PAINT ON THE INSIDE OF FRAME WHERE IT CONTACTS CURBING CONCRETE.
9. DRAINABLE FRAME, DRAIN FITTING SUPPLIED IN ONE CORNER, PLUMBED BY OTHERS.
10. LID IS HELD OPEN IN A 90 DEGREE POSITION WITH A LOCK OPEN ARM. ARM IS MANUALLY RELEASED TO CLOSE HATCH.
11. GAS SPRING ASSIST ON DOOR MANUFACTURED FROM 316 STAINLESS AND FILLED WITH FOOD GRADE OIL.
12. STAINLESS FLUSH LIFT HANDLE IS SUPPLIED AND IS FLUSH WHEN NOT IN USE.
13. SLAM LOCK LATCH IS PROVIDED WITH A TAMPER PROOF PLUG INSTALLED IN LID, COMES WITH A TEE HANDLE TO REMOVE PLUG AND ACTUATE SLAM LOCK.

THIS DOCUMENT CONTAINS PROPRIETARY, TRADE SECRET, INFORMATION THAT IS THE PROPERTY OF VERSA STEEL, INC. THE INFORMATION CONTAINED IN THIS DOCUMENT, INCLUDING THE PRINCIPLE OF DESIGN, MAY NOT BE USED OR COPIED, IN WHOLE OR IN PART, WITHOUT THE EXPRESS PRIOR WRITTEN CONSENT OF VERSA STEEL, INC.

| | | |
|--|-------------------------------------|--|
| VERSA STEEL, INC. 1618 NE FIRST AVENUE PORTLAND, OREGON 97232 (503)287-9822 FAX (503)-287-7483 | | G F E D C B A REV ISSUED FOR DATE BY |
| DRAWN BY | | E.BAILIFF |
| DATE | | 2010-11-24 |
| CHECKED BY | | |
| APPROVED BY | | |
| MATERIAL | FINISH | SHEET TITLE |
| | | HATCH ASSEMBLY, FW300 SERIES 24 X 36 |
| PART NUMBER | PART NUMBER: VSH-FW300-A-24-36-S-GS | |
| VSH-FW300-A-24-36-S-GS | SUPPLIER | |
| SCALE | 1:16 | |
| DRAWING NO. | VSH-FW300-A-24-36-S-GS-SI | |
| REVISION NO. | A | |
| SHEET NO. | 1 OF 2 | |

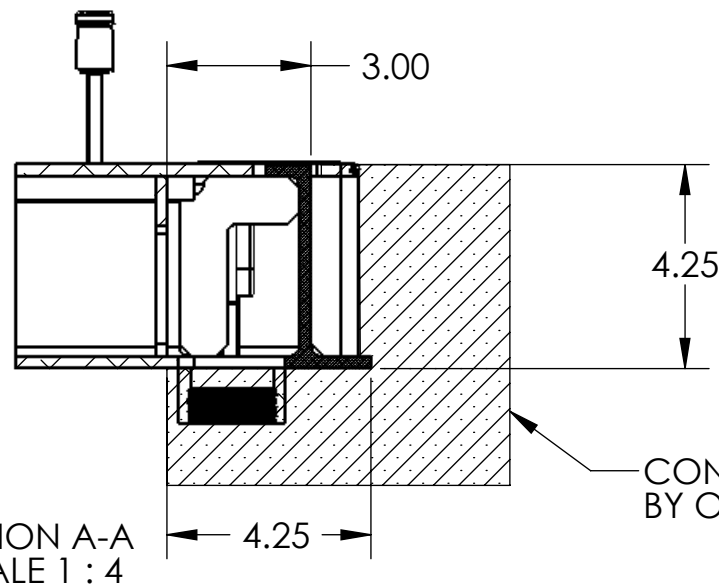
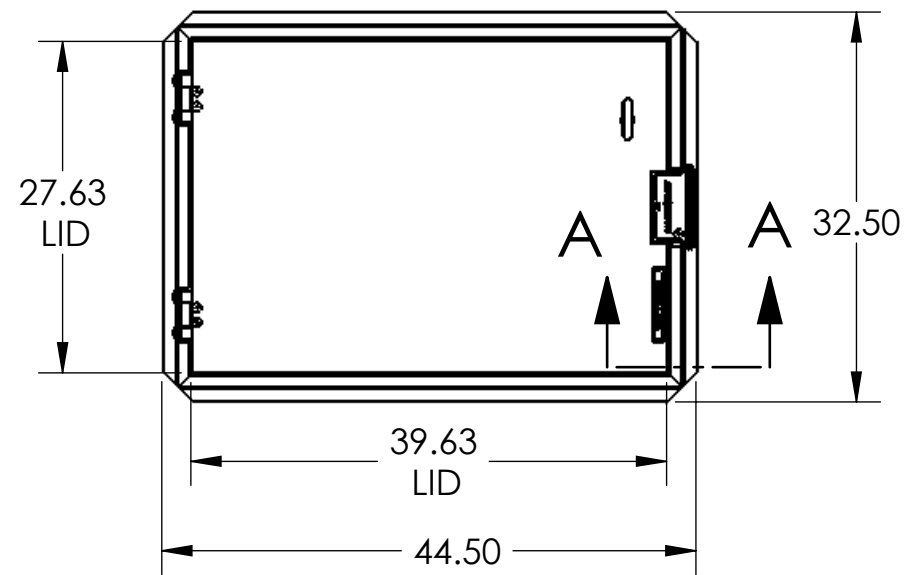

CONCRETE CURBING
BY OTHERS.

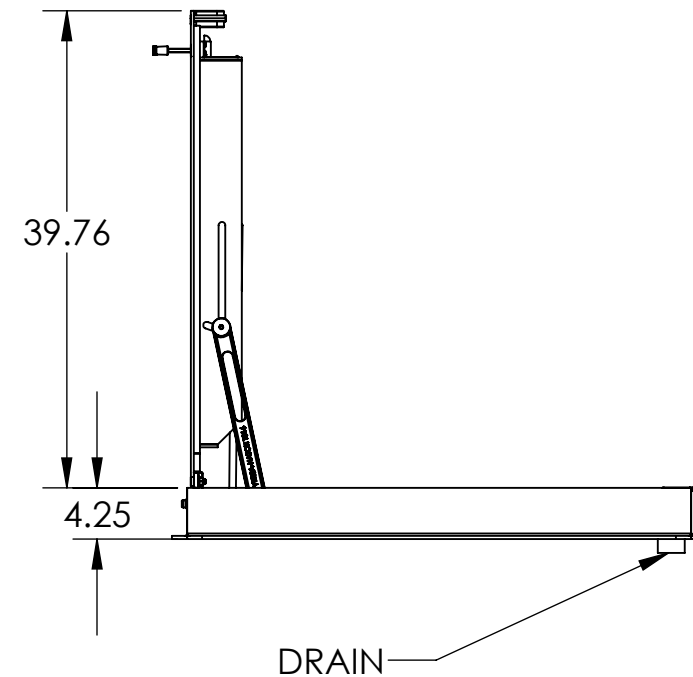
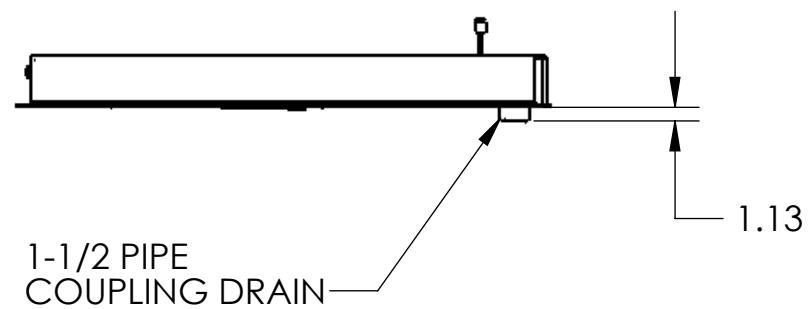
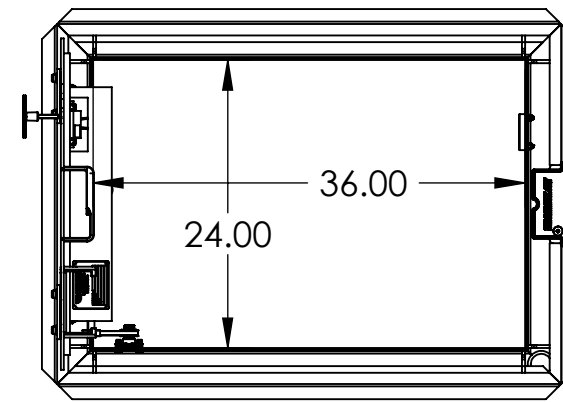

NOTES:
 PN: VSH-FW300-A-24-36-S-GS
 DESC: HATCH ASSEMBLY, FW300 SERIES 24 X 36
 MATRL:
 EST. WT: 96.07
 FINISH:
 NOTE:
 CAD FILE: VSH-FW300-A-24-36-S-GS-SPEC

THIS DOCUMENT CONTAINS PROPRIETARY, TRADE SECRET INFORMATION THAT IS THE PROPERTY OF VERSA STEEL, INC. THE INFORMATION CONTAINED IN THIS DOCUMENT, INCLUDING THE PRINCIPLE OF DESIGN, MAY NOT BE USED OR COPIED, IN WHOLE OR IN PART, WITHOUT THE EXPRESS PRIOR WRITTEN CONSENT OF VERSA STEEL, INC.

VERSA STEEL, INC.
 1618 NE FIRST AVENUE
 PORTLAND, OREGON 97232
 (503)287-9822
 FAX (503)-287-7483

DRAWN BY
 E. BAILIFF
 DATE
 2010-11-24
 CHECKED BY

APPROVED BY

MATERIAL
 FINISH
 SHEET TITLE
 HATCH ASSEMBLY, FW300 SERIES 24 X 36
 PART NUMBER
 VSH-FW300-A-24-36-S-GS
 SUPPLIER
 PART NUMBER
 VSH-FW300-A-24-36-S-GS
 SCALE
 1:16
 DRAWING NO.
 VSH-FW300-A-24-36-S-GS-S
 REVISION NO.
 A

SHEET NO.
 2 OF 2

| REV | ISSUED FOR | DATE | BY |
|-----|------------|------|----|
| G | | | |
| F | | | |
| E | | | |
| D | | | |
| C | | | |
| B | | | |
| A | | | |