

# VERSA STEEL Approval Drawings

## HATCH ASSEMBLY, DOUBLE LEAF 48 X 48

Assembly No.: VSH-150-A-48-48-D-NS

ASSEMBLY NO./PART NUMBER KEY:

VSH= VERSA STEEL INC. HATCH  
 150 = 200 P.S.F. RATED  
 A= ALUMINUM CONSTRUCTION  
 30-30= SIZE INTERIOR OPENING  
 S = SMALL SERIES  
 GS= GAS SPRING  
 NS= NO SPRING ASSIST

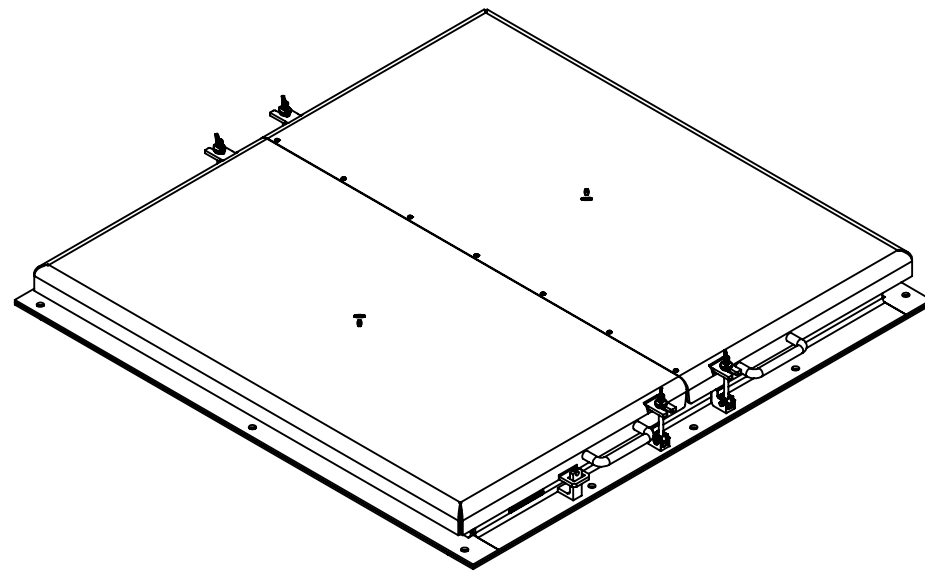

GENERAL SPECIFICATIONS:

1. UNIT IS WEATHER PROOF WITH CONTINUOUS BULB SEAL ON LID TO FRAME AND 1/4" X 3" WIDE FRAME TO CURB SEALS.
2. LID OVER LAPS FRAME A MINIMUM OF 2 INCHES.
3. FRAME IS A MINIMUM OF 4" ABOVE THE CURB.
4. LID IS HINGED ON SIDE WITH TAMPER PROOF SCREWS . THERE ARE A MINIMUM OF THREE SWING BOLT HOLD DOWNS TO SECURE THE HATCH FOR WEATHER PROOF SEAL.
5. HATCH IS DESIGNED FOR 150 P.S.F. LOAD.
6. THERE ARE 8 EXTERIOR ATTACHMENT POINTS FOR 1/2" FASTENER. THERE IS A FULL FACE GASKET OF 3" WIDE CLOSED CELL FOAM EPDM BETWEEN FRAME AND CURB.
7. LID IS A 1/4" 5086 FORMED ALUMINUM TREAD PLATE.
8. ALL FASTENERS AND HARDWARE ARE 316 STAINLESS STEEL.
9. ONE COAT OF BLACK BITUMINOUS PAINT ON THE INSIDE OF FRAME WHERE IT CONTACTS CURBING CONCRETE.

THIS DOCUMENT CONTAINS PROPRIETARY, TRADE SECRET INFORMATION THAT IS THE PROPERTY OF VERSA STEEL, INC. THE INFORMATION CONTAINED IN THIS DOCUMENT, INCLUDING THE PRINCIPLE OF DESIGN, MAY NOT BE USED OR COPIED, IN WHOLE OR IN PART, WITHOUT THE EXPRESS PRIOR WRITTEN CONSENT OF VERSA STEEL, INC.

|  |                                     |
|--|-------------------------------------|
| VERSA STEEL, INC.<br>1618 NE FIRST AVENUE<br>PORTLAND, OREGON 97232<br>(503)287-9822<br>FAX (503)-287-7483 |                                     |
| DRAWN BY   | E. BAILIFF                          |
| DATE   | 2009-08-05                          |
| CHECKED BY   |                                     |
| APPROVED BY  |                                     |
| MATERIAL   |                                     |
| FINISH   |                                     |
| SHEET TITLE  | HATCH ASSEMBLY, DOUBLE LEAF 48 X 48 |
| PART NUMBER  | VSH-150-A-48-48-D-NS                |
| SUPPLIER   |                                     |
| SCALE  | 1:16                                |
| DRAWING NO.  | VSH-150-A-48-48-D-NS                |
| REVISION NO.   | A                                   |
| SHEET NO.  | 1 OF 2                              |

|     |   |            |    |
|-----|---|------------|----|
| REV | A | ISSUED FOR | BY |
| REV | B |            |    |
| REV | C |            |    |
| REV | D |            |    |
| REV | E |            |    |
| REV | F |            |    |
| REV | G |            |    |

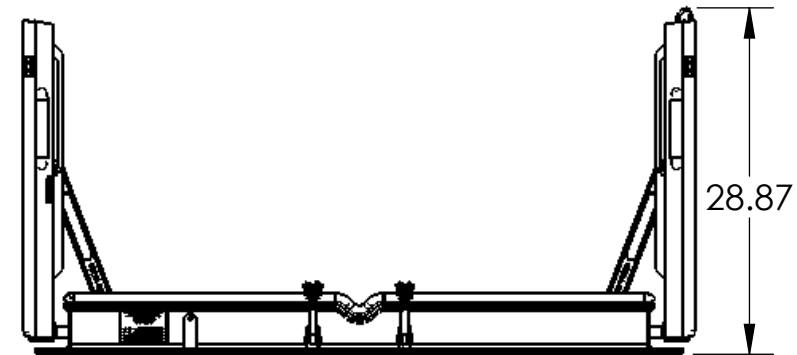
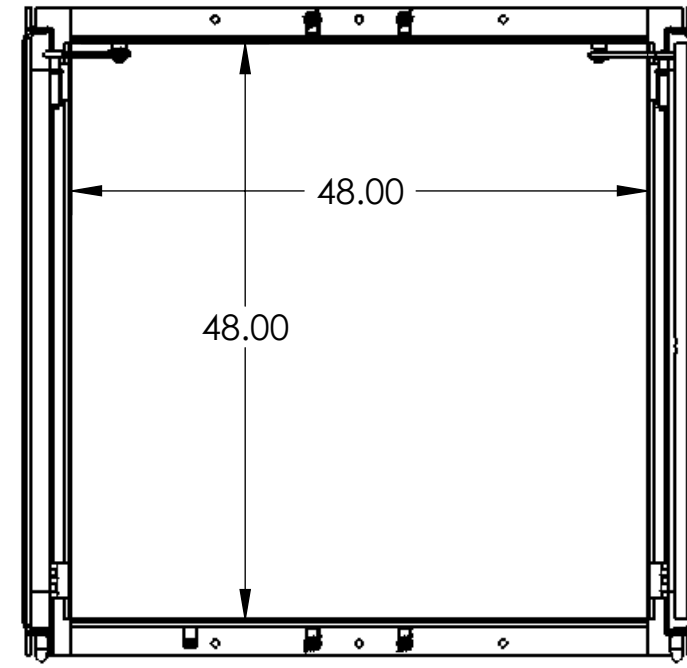
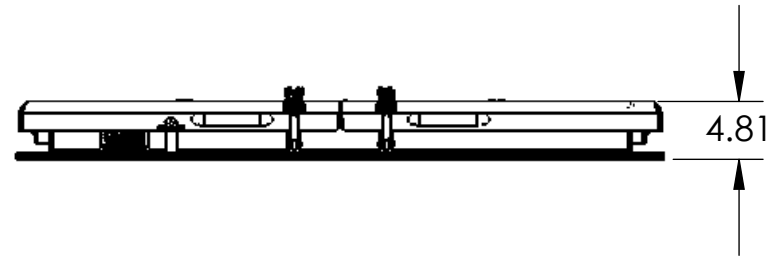
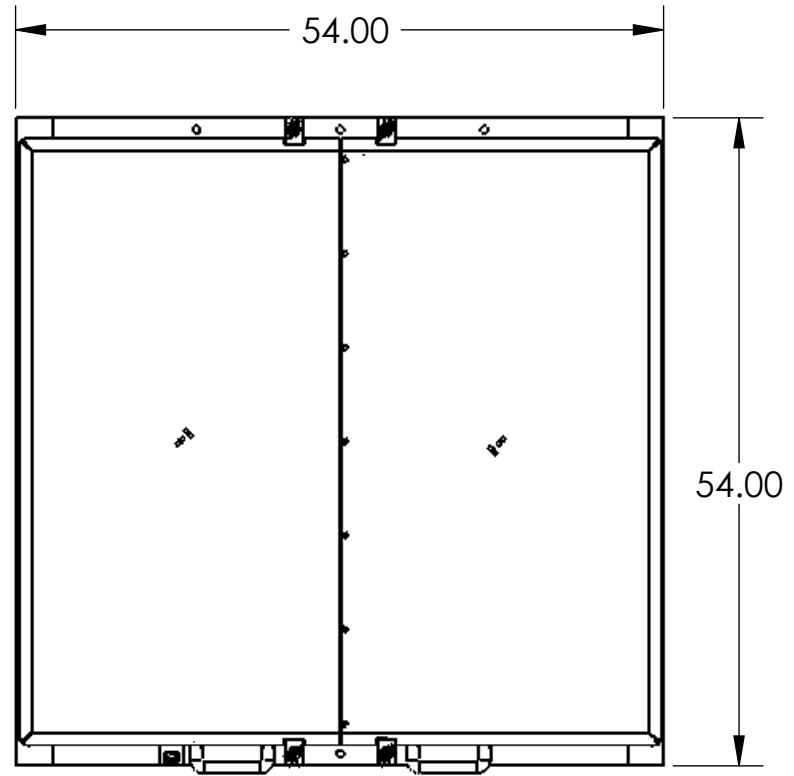

NOTES:  
 PN: VSH-150-A-48-48-D-NS  
 DESC: HATCH ASSEMBLY, DOUBLE LEAF 48 X 48  
 MATRL:  
 EST. WT: 109.16  
 FINISH:  
 NOTE: ERROR!:note  
 CAD FILE: VSH-150-A-48-48-D-NS

THIS DOCUMENT CONTAINS PROPRIETARY, TRADE SECRET INFORMATION THAT IS THE PROPERTY OF VERSA STEEL, INC. THE INFORMATION CONTAINED IN THIS DOCUMENT, INCLUDING THE PRINCIPLE OF DESIGN, MAY NOT BE USED OR COPIED, IN WHOLE OR IN PART, WITHOUT THE EXPRESS PRIOR WRITTEN CONSENT OF VERSA STEEL, INC.

|                                     |                      |  |
|-------------------------------------|----------------------|--|
| MATERIAL                            | PART NUMBER          |  |
| FINISH                              | VSH-150-A-48-48-D-NS |  |
| SHEET TITLE                         | SUPPLIER             |  |
| HATCH ASSEMBLY, DOUBLE LEAF 48 X 48 |                      |  |
| PART NUMBER: VSH-150-A-48-48-D-NS   |                      |  |
| SCALE                               | DRAWING NO.          |  |
| 1:16                                | VSH-150-A-48-48-D-NS |  |
|                                     | REVISION NO.         |  |
|                                     | A                    |  |
| SHEET NO.                           | 2 OF 2               |  |

VERSA STEEL, INC.  
 1618 NE FIRST AVENUE  
 PORTLAND, OREGON 97232  
 (503)287-9822  
 FAX (503)-287-7483

DRAWN BY  
 E. BAILIFF  
 DATE  
 2009-08-05  
 CHECKED BY

APPROVED BY

|     |            |      |    |
|-----|------------|------|----|
| REV | ISSUED FOR | DATE | BY |
| G   |            |      |    |
| F   |            |      |    |
| E   |            |      |    |
| D   |            |      |    |
| C   |            |      |    |
| B   |            |      |    |
| A   |            |      |    |